

# Dionysus

~ by Jennifer Thompson ~

Dionysus Mittens are fashioned with an all-over geometric pattern, a fitted cuff, and gusseted thumb. Instructions are given for a rounded closure at the tips of the fingers, a more traditional mitten top (*pictured*), as well as an option for fingerless mittens.



**Difficulty Level:** Intermediate → pattern uses i-cord cast on, increases, decreases, working from charts, knitting in the round, grafting, and stranded knitting.

## Materials Needed

**Yarn:** Approximately 276 {322, 382} yards in fingering weight yarn in two colors: for Main Color 120 {140, 156} yards; for Contrasting Color 156 {182, 226} yards. *Recommended yarn:*

- Knit Picks Palette (Fingering, 100% wool, 231 yards per skein)
  - For Main Color: 1 skein (Bluebell colorway)
  - For Contrasting Color: 1 skein (Raspberry Heather colorway)

**Needles:** Size to achieve proper gauge. (For fingerless mitten option, a set of double pointed needles in a size smaller than the below specified is also needed).

- For small, set of 2.25mm (US 1) double pointed needles (DPNs)
- For medium, set of 2.75mm (US 2) double pointed needles (DPNs)
- For large, set of 3.25mm (US 3) double pointed needles (DPNs)

**Gauge:** Using corresponding needles listed above, in stranded colorwork pattern Chart A, after blocking. **Take time to check gauge.** See last page for information on blocking.

- For small, 11 stitches x 12 rows = 1" x 1"
- For medium, 10 stitches x 11 rows = 1" x 1"
- For large, 9 stitches x 10 rows = 1" x 1"

**Notions:** stitch holders / waste yarn, tapestry needle, stitch marker

**Pattern Support** → This pattern has gone through an extensive test knitting and tech editing process to ensure accuracy and clarity of instructions. If you find an error, or need clarification, please contact me by email or through my website.

Email: [jennifer.thompson@gmail.com](mailto:jennifer.thompson@gmail.com) Website: [www.fernknits.com](http://www.fernknits.com)

# Dionysus Mittens

## Abbreviations / Stitch Guide

CC → Contrasting Color

k → Knit

k2tog → Knit two stitches together

kfb (knit front back) → Knit into the front of the next stitch and then knit into the back of the same stitch

kfbf (knit front back front) → Knit into the front of the next stitch, then knit into the back of the same stitch, and then knit into the front again of the same stitch

m → Marker

MC → Main Color

M1L (make one left) → Insert the left needle from front to back into the horizontal strand between the last stitch worked and the first stitch on the left needle. Knit this strand through the back loop to twist the stitch.

M1R (make one right) → Insert the left needle from back to front into the horizontal strand between the last stitch worked and the next stitch on the left needle. Knit this strand through the front loop to twist the stitch.

pm → Place marker

p → Purl

RS → Right Side

WS → Wrong Side

**Yarn Dominance** → Yarn dominance is critical to the success of stranded knitting, and involves holding each strand of yarn in a consistent way so that one color remains dominant throughout the knitting. The dominant yarn will be the yarn that is carried under the other yarn; in essence, the dominant yarn is pushed forward by the other yarn and appears slightly larger (more dominant) than the other yarn. If you hold the yarn using two hands, typically the yarn held in the left hand will be dominant. If you hold both yarns in one hand, typically the yarn held at the back will be dominant. Be sure to always hold the same yarn dominant. For the mittens pictured, the CC yarn was held dominant.

## Schematic

- A. Wrist Circumference: 6.5" {7.5", 8"} around
- B. Palm Circumference: 7.25" {8", 8.75"} around
- C. Length of Mitten Body (from top of thumb gusset): 5" {5.5", 6"}  
C. **(1)** Length of Mitten Body for Fingerless Mittens: 2.5"
- D. Thumb Length: 2" {2.5", 3"}

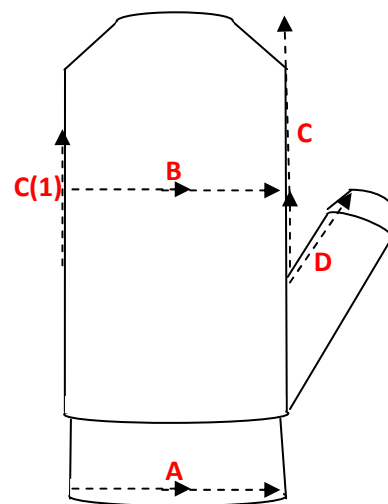

# Dionysus Mittens

## Charts

(Note, charts are to be read from right to left)

## Stitch Key

	Main Color (MC)
	Contrasting Color (CC)
L	M1L
R	M1R

### Chart A/D: Cuff / Thumb

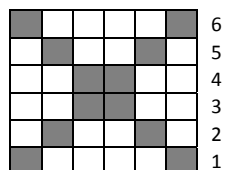

### Chart B: Mitten Body

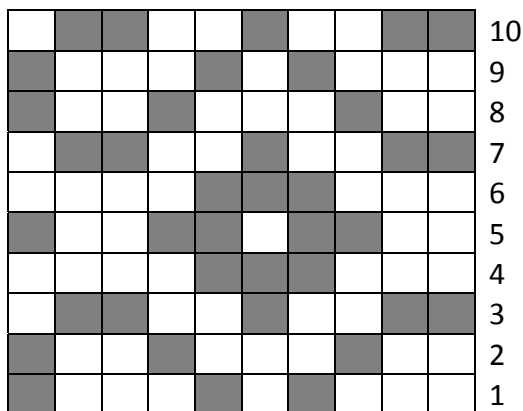

### Chart C: Thumb Gore

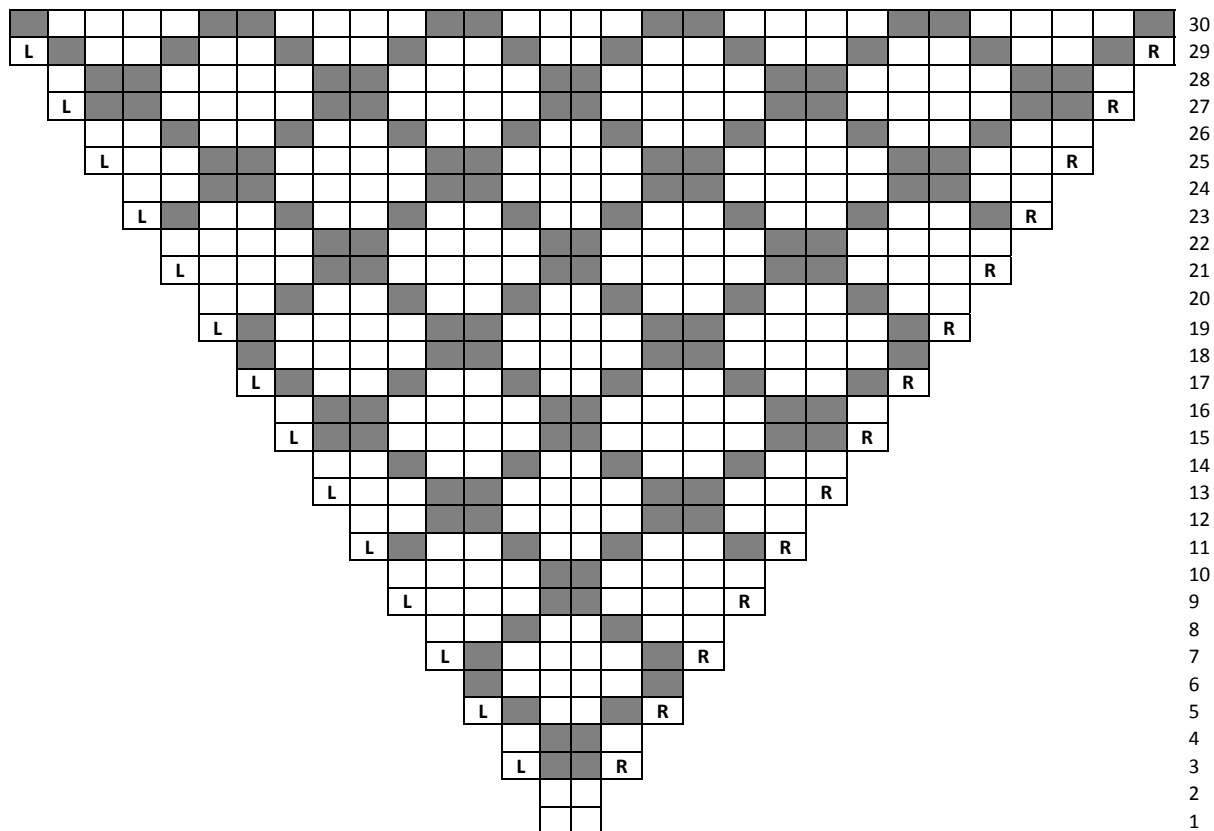

# Dionysus Mittens

---

## **Directions**

For size small {medium, large}.

### **Cuff**

- With CC, work i-cord cast on as follows:

#### **i-cord cast on → (using double pointed needles)**

- Leaving six inches of tail for grafting later, cast on 3 stitches.
  - Row 1 (RS): kfb, k2 (4 stitches).
  - Slip 3 stitches from right needle to left, leaving 4<sup>th</sup> stitch on right needle.
  - Row 2 (RS): kfb, k2 (5 stitches).
  - Slip 3 stitches from right needle to left, leaving 4<sup>th</sup> and 5<sup>th</sup> stitches on right needle.
  - Continue i-cord cast on until you have 72 stitches on the right needles (spread evenly along 3 or 4 double pointed needles) and 3 stitches on left needle.
  - Using the six inches of tail left from cast on, graft the 3 stitches on left needle to beginning 3 stitches from initial cast on, thus joining for working in the round, being careful not to twist stitches.
- With CC, knit one round
  - Work Chart A across 72 stitches, using CC for the dark boxes and MC for the light boxes, repeating rounds of Chart A until cuff measures 2.5" {3", 3.5"} long, or desired length of cuff.
  - Next round, with CC, knit all stitches.

### **Mitten Body**

- Next round, with CC, \*k8, kfb\*\* (repeat from \* to \*\* to end, total 80 stitches).
- Next round, work Chart B across 80 stitches, pm, kfbf with CC (82 stitches).

### **Mitten Body & Thumb Gore**

- Next round, work Chart B across 80 stitches, slip m, work Chart C for thumb gore.  
Repeat this round, using M1R as increase method for right side and M1L as increase method for left side when needed for Chart C, until 30 rows of Chart C have been completed. Place 30 stitches of thumb gore onto waste yarn or stitch holder.
- From here, select from the mitten options identified on the next page and go to the corresponding section.

# Dionysus Mittens

## Options

### Rounded Top

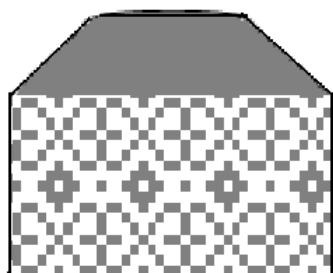

### Traditional Top

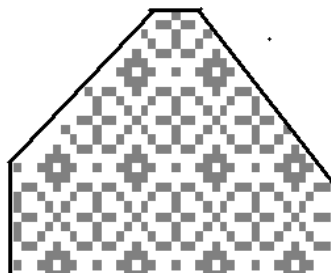

### Fingerless

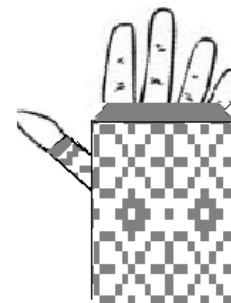

*(Please Note, these drawings are intended to identify the basic shape of the mitten options and are not drawn to scale. Refer to the schematic and finished measurements listed on Page 2 for accurate measurements).*

### Rounded Top ⇒ Mitten Body

- Continue working Chart B across 80 stitches until mitten measures approximately 4" {4.5", 5"} from the top of the thumb gusset.
- Break MC yarn.
- Next round, using only CC (optional: hold yarn double for a thicker and more durable top), \* k5, k2tog \*\* around (repeat from \* to \*\* around until there are 15 stitches remaining).
- Break yarn, leaving several inches of tail, and pull yarn through remaining stitches. Cinch tight and weave end of yarn into the inside of mitten.

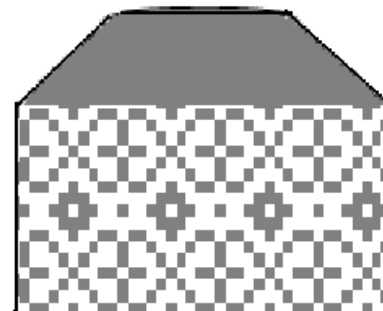

### Rounded Top ⇒ Thumb

- Pick up 30 stitches of thumb from waste yarn and spread stitches evenly across DPNs.
- Work Row 1 of Chart D across 30 stitches.
- Continue working Chart D across 30 stitches until thumb measures 1.5" {1.75", 2"} long, as measured from picked up stitches.
- Break MC yarn.
- Next round, using only CC (optional: hold yarn double for a thicker and more durable top), \* k5, k2tog \*\* around (repeat from \* to \*\* around until there are 10 stitches remaining).
- Break yarn, leaving several inches of tail, and pull yarn through stitches. Cinch tight and weave end of yarn into the inside of thumb.

# Dionysus Mittens

- Turn mitten inside-out and, using tapestry needle, sew closed the hole at the top of the thumb gusset.

## Rounded Top ⇨ Finishing

- Weave in all ends.
- Block → Immerse in cold water. Press water out of mittens. Gently tug at mittens to even out stranded work and correct tension. Lay mittens on a towel over a firm surface. Press down bottom of cuff at i-cord to ensure it dries flat, and fold towel over top of mittens. Place a heavy flat object (ie, a big book) over towel and leave overnight, or until dry.

## Traditional Top ⇨ Mitten Body

- Continue working Chart B across 80 stitches until mitten measures approximately 3.75" {4", 4.5"} from the top of the thumb gusset, and ending after Row 6 of Chart B.
- Next round, work Chart E (*below*) for the Mitten Top, noting that row 1 of Chart E roughly corresponds to Row 7 of Chart B.
- Continue working Chart E until there are 12 stitches remaining, or until desired length of mitten.
- Graft remaining stitches together and weave end of yarn into the inside of mitten.

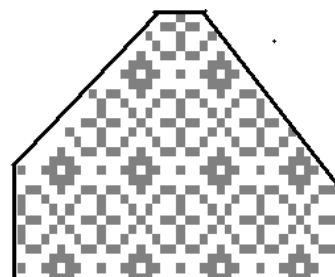

### Stitch Key

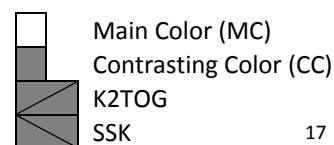

### Chart E: Mitten Top

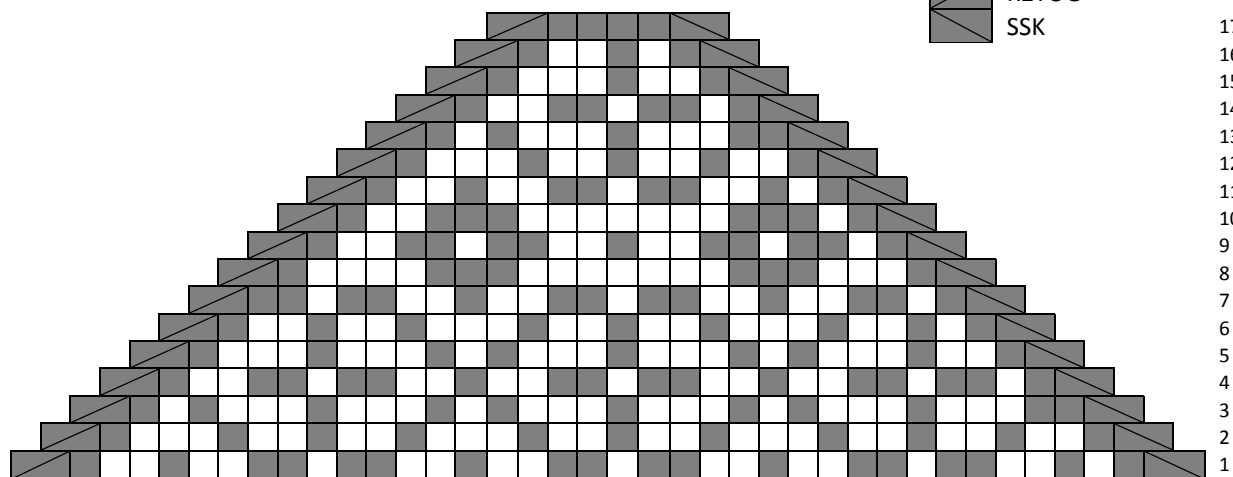

# Dionysus Mittens

---

## Traditional Top ⇨ Thumb

- Pick up 30 stitches of thumb from waste yarn and spread stitches evenly across DPNs.
- Work Row 1 of Chart D across 30 stitches.
- Continue working Chart D across 30 stitches until thumb measures 1.5" {1.75", 2"} long, as measured from picked up stitches.
- Break MC yarn.
- Next round, using only CC (optional: hold yarn double for a thicker and more durable top), \* k5, k2tog \*\* around (repeat from \* to \*\* around until there are 10 stitches remaining).
- Break yarn, leaving several inches of tail, and pull yarn through stitches. Cinch tight and weave end of yarn into the inside of thumb.
- Turn mitten inside-out and, using tapestry needle, sew closed the hole at the top of the thumb gusset.

## Traditional Top ⇨ Finishing

- Weave in all ends.
- Block → Immerse in cold water. Press water out of mittens. Gently tug at mittens to even out stranded work and correct tension. Lay mittens on a towel over a firm surface. Press down bottom of cuff at i-cord to ensure it dries flat, and fold towel over top of mittens. Place a heavy flat object (ie, a big book) over towel and leave overnight, or until dry.

---

## Fingerless ⇨ Mitten Body

- Continue working Chart B across 80 stitches until mitten measures 2" from the top of thumb gusset, or desired length.
- Break MC yarn.
- Next round, using only CC and a smaller set of needles, \* k1, p1 \*\* (repeat from \* to \*\* to end).
- Repeat last round five more times.
- Bind off loosely, break yarn, and weave into the inside of mitten.

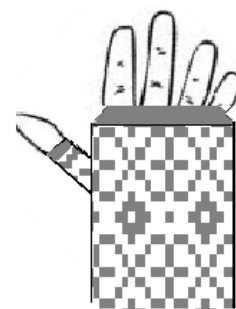

# Dionysus Mittens

---

## Fingerless ⇒ Thumb

- Pick up 30 stitches of thumb from waste yarn and spread stitches evenly across DPNs.
- Work Row 1 of Chart D across 30 stitches.
- Continue working Chart D across 30 stitches until thumb measures 1" {1.25", 1.5"} long, as measured from picked up stitches.
- Next round, using only CC, \* k1, p1 \*\* (repeat from \* to \*\* to end).
- Repeat last round five more times.
- Bind off loosely, break yarn, and weave into the inside of mitten.
- Turn mitten inside-out and, using tapestry needle, sew closed the hole at the top of the thumb gusset.

## Fingerless ⇒ Finishing

- Weave in all ends.
- Block → Immerse in cold water. Press water out of mittens. Gently tug at mittens to even out stranded work and correct tension. Lay mittens on a towel over a firm surface. Press down bottom of cuff at i-cord to ensure it dries flat, and fold towel over top of mittens. Place a heavy flat object (ie, a big book) over towel and leave overnight, or until dry.