



Pocket Prims Pattern

[a Gingermelon design](#)

List of Supplies

Doll

- : 10x20 inches cotton fabric (not jersey) for doll's body
- : 2x 14mm black buttons for eyes (9/16 inch)
- : Embroidery thread/floss
- : Sewing machine/thread
- : Scissors, pins/needles, embroidery scissors
- : Disappearing ink marker, ruler
- : Polyfil/stuffing
- : Orange stick, wooden spoon for stuffing
- : Yarn for hair
- : Pink coloured pencil
- : Clear drying craft glue, Q-tip
- : Long doll needle

Outfits

- : 6x6 fabric for Basic Shirt
- : 5x6 fabric for Tunic or Dress Bodice
- : 3x11 fabric for Tunic Skirt
- : 3.5x11 for Dress Skirt
- : 4x10 fabric for Capri's
- : 4x6 fabric for Shorts
- : 2x2 felt for bow
- : Tiny hair clip
- : Lace trim, seam binding, pompom trim, Fray Check, tiny buttons, press studs, etc for embellishing

**** Please be sure to read through the entire pattern thoroughly before you begin.**

Instructions for Tracing and Cutting Out Pattern Pieces

: Print pattern onto regular printer paper, there is no need for re-sizing. Cut out all paper pattern pieces. The main Body, Head, Arms and Legs are going to be traced directly onto the fabric with your disappearing ink marker.

: Seams for each body part are machine stitched directly onto traced outlines of pattern pieces.

: For each of the outfit pieces, set your sewing machine on zig-zag, using the smallest stitch setting, and zig-zag around entire edge of each piece. **** Optional:** If you'd like frayed edges instead of hemmed edges on your capri's or shorts, omit zig-zaging around the opening of the leg area.

Transferring Pattern Pieces onto Fabric

Head

- : Fold fabric in half lengthwise, wrong sides facing. Carefully cut fabric along the the fold so that you now have two sides.
- : Trace Head pattern piece onto right side of your fabric with your disappearing ink marker,
- : To mark the grid on the face, keep Head pattern piece pinned in place and gently lift the outer edges of the pattern piece to mark the beginning of the lines onto the felt with your disappearing ink pen.
- : Remove pattern piece and use your ruler to connect the lines. These lines will serve as a guide for the eye, nose and mouth placement.

Body, Arms and Legs

- : Fold fabric in half lengthwise, right sides facing and trace pattern pieces for Body, Arms and Legs onto fabric with your disappearing ink pen, making sure to transfer all markings onto the body and arms. As with the head, carefully cut fabric along the fold so that you have two slices of fabric facing each other.
- : Pin front and backs of fabric together.



Face

: Transfer facial markings onto the right side of the face with your disappearing ink marker using your Head pattern piece as a guide.

: Begin by sewing the eye buttons in place on the top marked line where the outermost vertical lines meet.

: Embroider the nose onto the face using one strand of embroidery thread/floss. I alternated the straight horizontal stitches with two different colours of thread to add a bit of interest.

: Stitch the mouth in place using two strands of embroidery thread/floss.

: Embroider the eye lashes beneath the button eyes and the eyebrows above using one strand of thread/floss.

; Now, re-draw the rounded outline of the head on the right side of the fabric with your disappearing ink marker to darken the line. Mark the dots at the top of the head for the opening. You should be able to see the outline of the head on the wrong side of the fabric once it's flipped over.



: Flip head fabric pieces over so that the right sides are facing each other. Use your disappearing ink pen to re-draw the rounded outline of the head onto the wrong side of the fabric. Pin front and back of fabric together.



: Set your sewing machine stitch to straight stitch, and use a small stitch setting – I like to keep mine between 1 and 1.5. This makes a nice strong seam that should withstand the stuffing process, as well as lots of cuddles!

: Place fabric onto the bed of the sewing machine. The needle should align perfectly with the edge of the traced outline at the top of the head where the dot on the right begins. Sew directly onto marked line, starting and ending your seam with a back stitch and leave a long tail of thread for sewing up the opening later on.



: Trim excess fabric around sewn edges, leaving a little tab between dots at the top of the head. Turn right side out and press.

: Stuff head, making sure it's nice and full, but not to the point of bursting at the seams. Tuck tabs in and pin seam together. Ladder stitch opening closed.



Body, Arms and Legs

: Repeat sewing process for body, arms and legs, again leaving the area between the marked dots open for turning and stuffing. Trim excess fabric around pieces and turn right side out. Stuff body and arms and ladder stitch openings closed.



Legs

: Stuff legs, working your way up from the foot to about $\frac{1}{4}$ of an inch below the marked line. Position seam so that it is running down the center front and back of the leg. Tuck in tabs at the top of each leg, pin together and ladder stitch openings closed.

: Pin legs to bottom seam of body and ladder stitch front and back of each leg onto seam.



Attaching Arms to Body

: Pin arms to sides of body. Using your long doll needle threaded with two strands of embroidery thread, insert needle underneath one arm and bring it through the body and out through the other arm. Insert needle into the same arm, imagining if you will, that you are sewing two-holed buttons on at the top of each arm. Go in through the body again and out through the opposite arm in the same manner, repeating the process a few more times and end off underneath an arm.



Attaching Head to Body

: If necessary, re-draw the center line onto the body as well as the dashed line on the neck area. You may also have to re-draw the center line onto the lower part of the face.

: Position head onto neck, aligning the bottom seam of the head onto the dashed line on the neck, and matching the center line of the face with the center line of the body. Pin in place, inserting pins through the front of the head and out through the back of the neck.



: With the doll facing you, bend the head over slightly and insert a threaded needle just below the top seam of the neck and out through the top left hand corner of the neck.



: Turn the doll so that the back of the head is facing you. Working from right to left, start ladder stitching the head onto the neck, keeping your stitches small and neat.

: Keep stitching the head onto the neck, working your way around the head and neck and using the marked line on the front of the neck as a guide for stitching the head onto the front of the neck.

: Continue ladder stitching around a second time, this time stitching a couple of millimeters further away from the original stitches. This will bring the head closer onto the neck and the head will be a lot more stable.



Hair

: Wrap yarn around a shoe box lid. (My strands measured about 20 inches in length once the ends were cut and I had roughly about 60 strands).



: Carefully slide yarn off the box, keeping all strands even and tie the center of the bundle with a piece of yarn in a contrasting colour. (Don't make a knot). Cut the loops on each end of bundle so that hair is straight on either end.



: Position bundle of yarn directly onto the head seam, centering it in the middle of the seam and pin in place.



: To attach the yarn bundle onto the head, double thread a needle with embroidery thread to match the colour of her hair. Insert needle through the back of her head, into the fabric just below the head seam beneath the yarn bundle. Bring it out through the front of the head, directly below the head seam under the yarn bundle. Pull thread firmly as you go.

: Repeat as above a few times to secure the yarn bundle onto the head seam. Remove the contrasting yarn tie in the center of the bundle. End off thread at the back of the head.



: Gather all the hair and get it up and out of the way. Apply a layer of craft glue to the back of her head with a clean Q-tip, spreading it on evenly to coat the entire area.

: Working from the center to either side, carefully place individual strands of yarn onto the glued area so that the back of the head is completely covered from side to side. Use a Q-tip to gently push each strand down into the glue.

: Allow to dry thoroughly.



: Trim ends of hair and cut a fringe in front if desired.

: Separate hair into two sections on either side of her head and tie each bundle with narrow ribbon or pretty thread.

: To cut short hair, gather up the loose yarn from the top bundle and get it up and out of the way. You'll then be left with the layer of hair that has been glued onto the head. Determine how short you'd like to go and carefully trim the hair, starting at the center back and working out to each side. Arrange the top layer down onto the bottom layer and cut it to match the layer you've already cut.



: Gently rub your pink coloured pencil into the cheek area adding layers of colour. Use your finger to gently smudge it in for a softer look.



Outfits

There are a few different tops and bottoms to choose from which can be mixed and matched to create a variety of different outfit combinations for your doll. These can be embellished however you choose, with pretty trims, tiny buttons and/or embroidered details – it's all up to you!

Tops



Basic Top, Tunic or Dress

: Fold bodice/basic top fabric in half lengthwise, right sides facing. Align bottom edges (*) and side edges(") and pin along the curved edge on either side. These are the underarm seams.

: Machine sew underarm seams, leaving a ¼ inch seam. Notch curves.

: Hem sleeves.



** To complete the basic top, hem bottom edge. Fold over a tiny hem along the neckline and carefully stitch in place. You can do the same along the back sides of the top, but I've left mine with the zig-zagged edges to give it a rustic look. Sew a press stud on either side of the back of the neck area.

Tunic or Dress Cont.

: To make the skirt for either the tunic or dress, set machine stitch on longest setting and stitch two rows of gathering stitches about 1/4 inch below top edge of skirt.

: Fold skirt in half and mark center (right side of fabric) with your disappearing ink marker.



: With right sides facing, pin top edge of skirt onto bottom edge of bodice, starting at the center and working your way out to the sides. Gently pull gathers on either side of skirt while you pin it onto the top. Use the back of a needle to spread your gathers evenly across the skirt so that they're not all bunched up in one area.



: Set machine stitch on regular stitch and position fabric so that the the edge of the foot is aligned with the bottom edge of the bodice. Carefully sew across the entire length. Remove gathering thread.



: Press edge up towards bodice.

: Fold tunic/dress in half, right sides facing and pin skirt sides together. Sew skirt sides together, stopping at the stitched line at the waistband. Press edges open and turn right side out.

: To complete, hem bottom edge of dress or tunic, adding lace trim if desired. Fold over a tiny hem along the neckline and carefully stitch in place. You can do the same along the back opening of the bodice. Sew a press stud on either side of the back of the neck area.



Bottoms

The shorts and capri's are basically sewn up in the same manner, though it's up to you whether you'd like hemmed pant legs or a frayed edge. Adding a pretty trim is another option as is adding embroidered details to the hem.

A simple embroidery thread/floss drawstring is threaded onto the waistband for easy closure.



Capri's and Shorts

: Place pants pieces together, right sides facing and pin together.

: Starting on the right hand side, stitch down from the waistband at A. and around the curve of the crotch to B. Repeat on the left hand side.



: With right sides of fabric facing, open pants so that center seams are matching at B. Pin at center (B.) and inner legs.

: Sew inner leg seam from C. to C.



: Fold waistband over about $\frac{1}{4}$ of an inch and pin. Use contrasting embroidery thread to stitch down.

: Turn right side out and hem edges of leg openings if desired, or use the sharp end of a needle to gently pull some width-wise running threads loose from the fabric. You can embellish the hem with contrasting embroidery thread, lace trim, etc.

: Double thread a needle with embroidery thread and make a drawstring for the waistband.



Bow

: Fold bow in half. Blanket stitch the two short ends together.

: Fold bow so that the blanket stitches run down the center.

: Position short edge of Bow Center onto the center of the blanket stitches. Whip stitch short edge onto center of blanket stitches.

: Wrap the bow center around over the front of the Bow, and overlap the opposite short edge onto the stitched edge. Stitch onto a tiny metal hair clip.



Congratulations!! You have just created a perfectly adorably little doll!!! I hope you've enjoyed making her and I'd love to see how she's turned out! If you have any questions along the way, please contact me at md1911@shaw.ca. You are welcome to post pics on my facebook page too: <https://www.facebook.com/gingermelondolls>



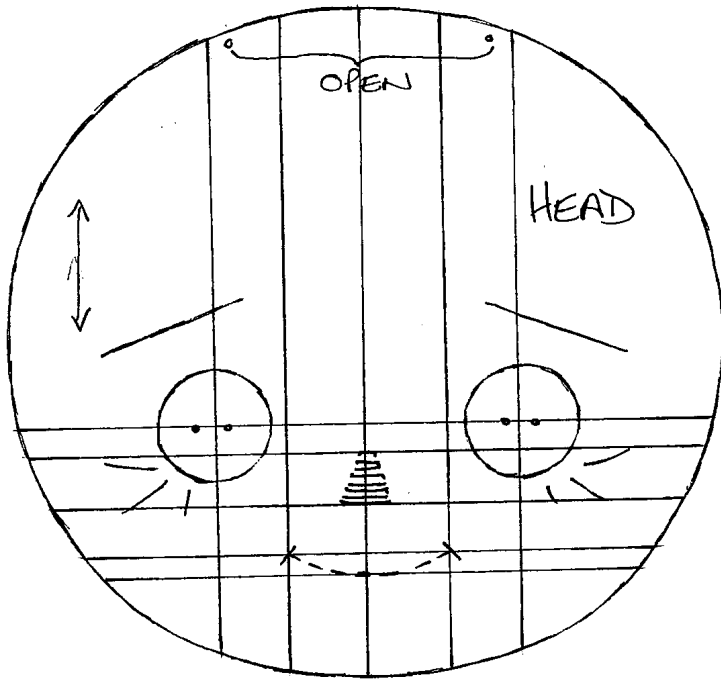

↑
 Direction of
 stretch on
 fabric
 ↓

