

# Peppermint

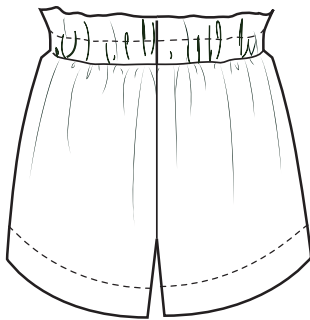

# The Fabric Store

PATTERN  
RUNWAY

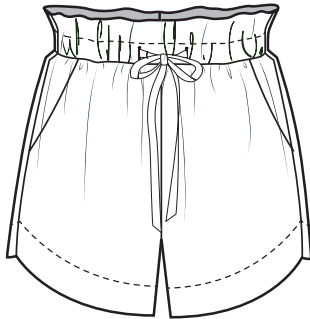

## SPRING SHORTS

# 1403

Launch into spring with these super cute and easy to wear elastic waist shorts. With a Paper-Bag waist and front side pockets, these little sweeties are sure to be a spring and summer wardrobe staple! Easy and quick to sew with a relaxed fit and a gently curved hemline.

**SUGGESTED FABRICS:** Light weight to medium weight fabrics that drape well. Such as cottons, chambray, lightweight linen, cotton blends, light weight silk.

**TRIMS:** 28mm Non-Roll Elastic, cord and beads for the tie.

**SEWING LEVEL:** Beginner

### Seam Allowances & Hems:

All seams are **1cm / 3/8"**

### Size Chart:

	8	10	12	14	16
Bust	84cm/33"	86.5cm/34"	89cm/35"	94cm/37"	99cm/39"
Waist	66cm/25½"	68.5cm/27"	71cm/28"	76cm/30"	81cm/32"
Hip	91.5cm/36"	94cm/37"	96.5cm/38"	101.5cm/40"	106.5cm/42"

### Fabric Requirements:

MAIN - m / yd	Wide Fabric: 150cm / 60"	Narrow Fabric: 115cm / 45"
Size 8, 10, 12	1.1m / 1 ¼ yd	1.5m / 1 ¾ yd
Size 14 + 16	1.2m / 1 ½ yd	1.6m / 1 ¾ yd

## BEFORE STARTING YOUR PROJECT:

Read all instructions carefully before starting on your project. Pattern Runway uses industrial sewing methods where appropriate to assist you in constructing a professional product, please note that some instructions will differ to traditional home sewing methods. We believe industrial methods will assist you in completing a perfect garment and in the quickest time.

We recommend pre shrinking all fabric by washing and drying it before you cut out your pattern, unless fabrics are dry-clean only such as suiting and wool.

We also recommend that you pre shrink any trims before using.

Make any pattern alterations such as lengthening or shortening before cutting your fabric.

Transfer all pattern markings to the wrong side of the fabric before removing the pattern pieces unless indicated. Consult the Pattern marking guide over the page.

Seam allowances for all wovens are **1.5cm / 5/8"** unless otherwise indicated.

Neaten seams using a Overlocker or a regular zigzag stitch.

We recommend that you press all seams as you go.

## GLOSSARY:

**Backstitch:** Sew in reverse for a maximum of 3 stitches, at the beginning and end of sewing every seam. This will prevent the stitches from coming undone.

**Gathering stitch:** Adjust your stitch length to the longest length on your sewing machine, usually around 4mm and loosen the sewing tension if necessary, stitch 1cm / 3/8" from the raw edge, then stitch again a small distance away from the first stitching, towards the raw edge. Pull both bobbin threads to gather the fabric to desired length, distributing the fullness evenly between start and finish, secure ends of threads by winding in a figure 8 around a pin inserted in the fabric. Once seams have been stitched remove gathering threads (if visible).

**Neatening the Seams:** Stitch a zig zag stitch over the raw edges of seam allowance, seams can be neatened together. Press towards the back of garment, an Overlocker/Serger can also be used.

**Edgestitch:** From the right side of the garment stitch a straight stitch close to the seam.

**Topstitch:** Sew a straight stitch on the outside of the garment parallel to the seam edge, usually 6mm / 1/4" away from seam, edge or previous stitching or as indicated.

**Understitch:** Press facing or lining away from garment and press the seam allowances towards the facing or lining. In the facing or lining, right side up, edgestitch close to the seam, this is to keep the lining or facing on the inside of garment and prevent it rolling to the right side.

## CREATING A PERFECT FIT:

### **How to Choose your Size:**

Choose your size by comparing your body measurements with those on our size chart and choose the size that closest matches your measurements. If your body measurements are in between sizes, we recommend that you choose the larger size, as its much easier to make a garment smaller! If your measurements are only slightly different than our size chart, then choose the closest size as all our patterns include wearing and style ease.

**PLEASE NOTE:** *that the size chart is not the finished garment measurements.*

We recommend that you also measure your body length and compare to the finished length measurements given. To achieve a perfect, individual fit, you may need to adjust patterns in length.

### **How to Measure the Body:**

- 1. Bust:** Measure around the back, under the arms and across the fullest part of the bust. Tape measure should be flat against the figure, straight across the back and not too tight.
- 2. Waist:** Measure around the waist, with the tape measure flat against the figure and snug but not too tight.
- 3. Hips:** Measure over the fullest part of the hips, usually 23cm / 9" down from the waist. The fullest part of the hip maybe higher or lower depending on the individual figure.
- 4. Back-Waist Length:** Measure from the nape of the neck, top of the back bone, to the natural waist.
- 5. Sleeve Length:** With the hand on the hip, Measure from the shoulder bone to the wrist.
- 6. In-Seam:** Measure from the Crotch to the desired hemline.  
*(you may need a friend to take this measurement accurately)*
- 7. Skirt Length:** Measure from the waist to the desired length,  
*(you may need a friend to take this measurement accurately)*

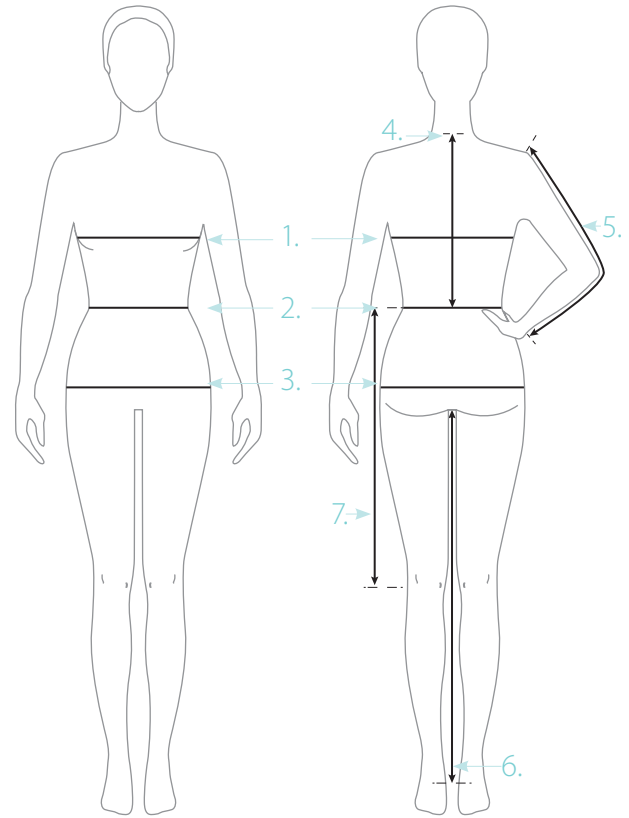

### MY MEASUREMENTS:

Bust: \_\_\_\_\_

Waist: \_\_\_\_\_

Hips: \_\_\_\_\_

Back-Waist length: \_\_\_\_\_

Sleeve Length: \_\_\_\_\_

In-Seam: \_\_\_\_\_

Skirt Length: \_\_\_\_\_

## LENGTHENING / SHORTENING:

Compare your length measurements with your selected size finished length measurements to determine the amount of adjustment needed.

### **To Lengthen a Bodice:**

Cut pattern along the lengthen shorten lines. Place a piece of paper under one pattern piece and tape in place. Extend the grainline on to the paper. Draw a parallel line on the paper, the measurement needed to add length. Tape the other part of the pattern, aligning the grainline and matching the edge along your drawn line, and tape in place. Connect the lines at the side and re draw the dart legs.

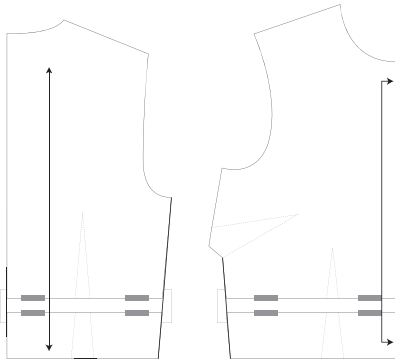

### **To Shorten a Bodice:**

Draw a line on your pattern piece the measurement of the decrease, parallel to the lengthen shorten line. Cut the pattern apart along the lengthen shorten line and overlapp the pieces to the drawn line. Tape in place. Re-draw the sides of the pattern piece, blending the line where needed, re draw the dart legs.

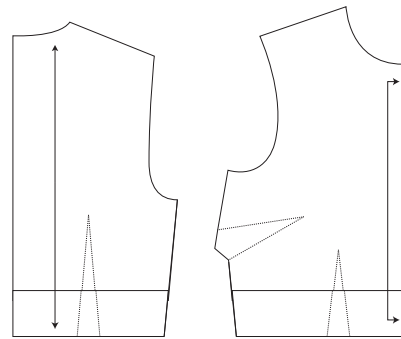

## PATTERN SYMBOLS:

←→ **Grainline:** When placing your paper pattern pieces on your fabric, the grain line or arrow must lie parallel to the selvages (woven edges) of the fabric.

↪ **Place on Fold:** A grainline marking, indicating that this line is placed on the fold of the fabric. Do not cut this line.

● **Dots:** Marks end of dart points, pocket placements, clip marks, etc, transfer markings to wrong side of fabric via, erasable marker, piecing the fabric with an awl or tailors chalk.

┌ **Notches:** Clip into the fabric where these markings are. These marks indicate matching points for pattern pieces, gathering directions and alignment directions. Make sure to clip no deeper than the notch marking and clip all notches as sewing instructions make reference to these marks.

× **Button / Snap**

—| **Buttonhole**

## CUTTING INSTRUCTIONS:

Cutting layouts show approximate position of pattern pieces, position may vary slightly according to pattern size. Lines shown are cutting lines and include all seam and hem allowances.

NARROW FABRICS: 115cm / 45"

**SIZE: 8, 10 + 12**

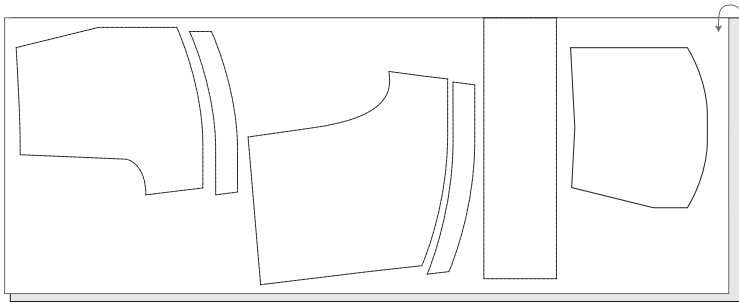

WIDE FABRICS: 150cm / 60"

**SIZE: 8, 10 + 12**

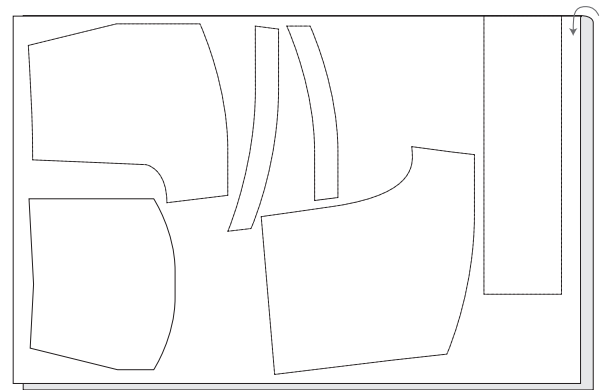

NARROW FABRICS: 115cm / 45"

**SIZE: 14 + 16**

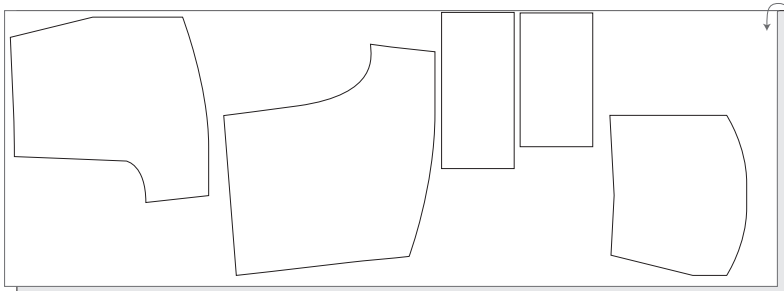

WIDE FABRICS: 150cm / 60"

**SIZE: 14 + 16**

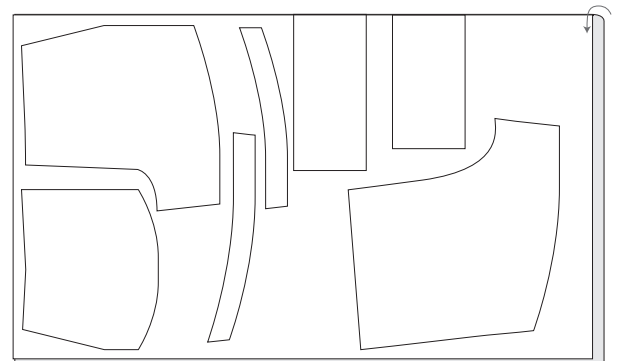

## SEWING INSTRUCTIONS:

### Key:

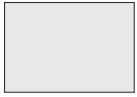

Right side

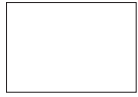

Wrong Side

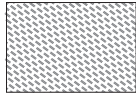

Fusing/Interfacing

### 1. Sewing the front pockets:

With right sides together, align the angled edge of the pocket and shorts, stitch the pocket edge with a 1cm seam.

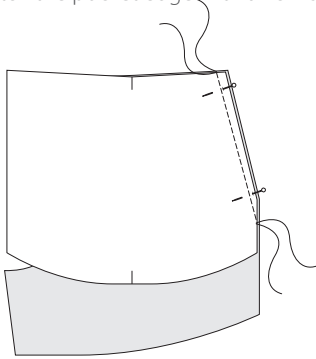

Turn pocket out flat, press seam allowances into the pocket, away from the shorts, understitch pocket, close to the pocket seam, through all seams.



Fold pocket in half, at the notches, match edges and press.

Finish the pocket by sewing the bottom of the pocket closed with a French seam: fold pocket wrong sides together, stitch a lower edge with a 6mm seam, trim seam to 3mm. Turn pocket right sides together and stitch with a 6mm seam.

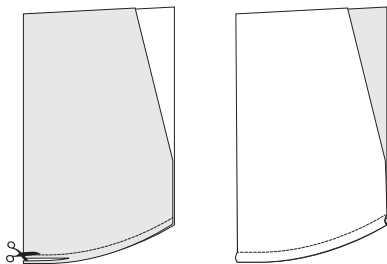

Press and baste side seams and waist edge to secure.

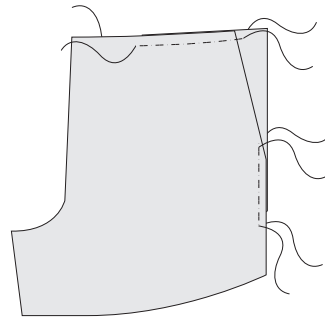

### 2. Joining the Legs:

With right sides together align and pin the corresponding shorts front to shorts back, stitching the side seam and in-seam with a 1cm seam. Neaten edges together and Press seam allowances to the back. Repeat for other leg.

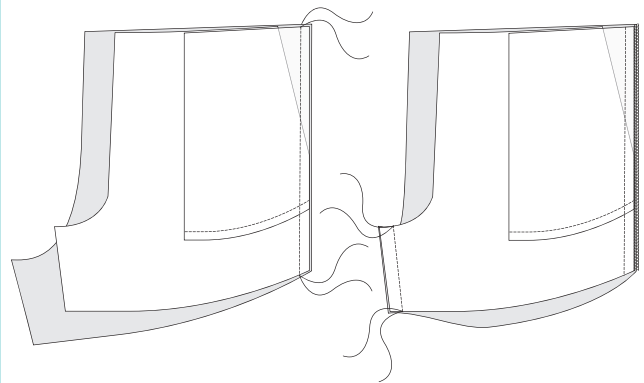

### 4. Sewing the Crotch

Neaten each crotch edge separately. We like to neaten the crotch seams separately instead of together, as the seam is quite curved which helps them lie flat.

With one leg right side out, and one leg wrong side out, slip the right side out leg inside the other. Match edges, seams and notches. Stitch the crotch seam with a 1cm seam. Stitch the crotch a second time either on top of the stitching or 3mm away, (*in the seam allowance*) to reinforce the seam, starting at the single notch on the front to double notch at the back. Stitching the seam a second gives a bit more strength to a high stress point of the garment. Press seams open.

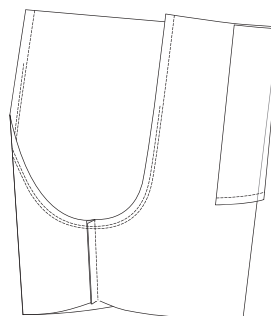

## 5. Attaching the Waistband

Transfer the button hole markings to the waistband and create two button holes according to your machine. Cut open the button holes with a button hole chisel.

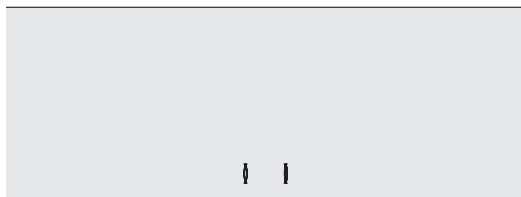

Neaten the opposite edge of the waistband. Fold the waistband in half lengthwise, wrong sides together, and press a crease in the centre.



Stitch the short ends of the waistband together with a 1cm seam and press the seam open without neatening.

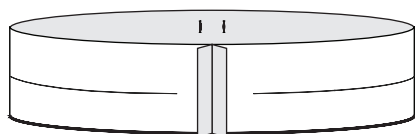

With the shorts right side out, unfold waistband and align and pin the waistband edge to the shorts waist. Align the button holes with the center front of the shorts and the waistband seam with the centre back seam. Stitch with a 1cm seam.

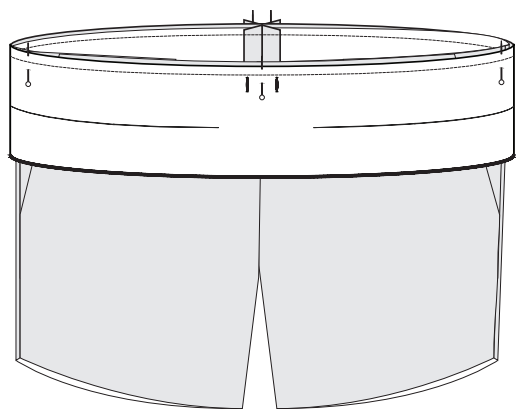

Turn and press waistband and seams up into the waistband away from the shorts. Trim intersecting seams to reduce the bulk. Fold waistband down, along the crease. Pin to secure, covering the seam.

**Stitch in the Ditch:** Working from the right side of the shorts, starting at the center back stitch in the ditch of the waistband,

through all layers, leaving approximately 5cm opening to thread elastic through.

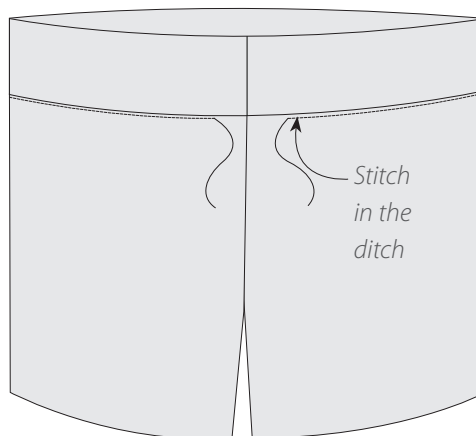

Create the Casing and 'Paper Bag waist' by stitching just sort of 3.5cm in from the folded edge of the waistband.

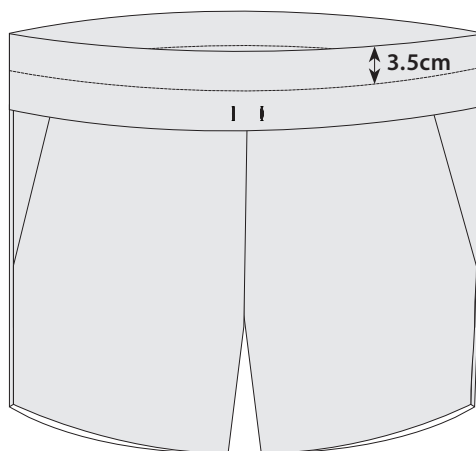

Thread elastic through the casing, try on the shorts to determine how tight you would like the elastic, trim to appropriate length. Overlap elastic ends by 2.5cm, ensuring the elastic is flat and not twisted, sew a rectangle to secure.

Close the casing opening by continuing stitching in the ditch. Evenly distribute the elastic through the waistband.

Insert a length of cord into the casing via the button holes, add beads and knot each end to secure.

## Sew the Hem bands

With right sides together, sew the corresponding front and back hem bands together at the side and in-seams. Press seams open.

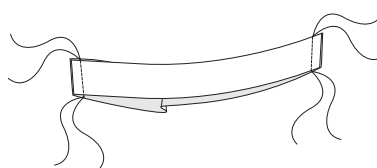

Neaten the upper edge of the hem band.

Place hembands on to shorts leg, right sides together. Stitch the seam with a 1cm seam. Trim seam allowance to 6mm. Turn and press hem bands to right side.

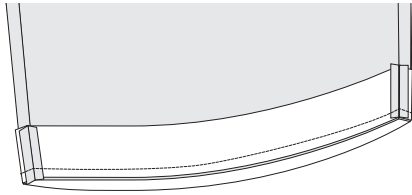

Understitch hemband, close to the seam through all layers.

Top stitch the hem band to shorts along upper hem band edge.

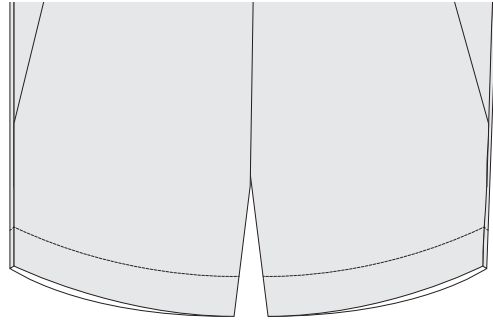

Give your gorgeous new shorts a final press and we recommend wearing immediately!!!



Peppermint



PATTERN  
RUNWAY

The Fabric Store

[www.patternrunway.com](http://www.patternrunway.com) | e: [patternrunway@gmail.com](mailto:patternrunway@gmail.com)

*Fall in love with HandMade*

**COPYRIGHT INFO:** This free pattern is for private home sewing use only. The images, layout, design and other aspects are protected by copyright and belong to Peppermint Mag 2015. If you wish to make and sell items from this pattern, please contact us for terms. Otherwise no part of this design or pattern may be reproduced commercially in any form.

## PRINTING

Our patterns are made to fit both US Letter + A4 Printing paper. **Open** the files using a PDF viewer. We recommend using **Adobe Reader** or **Adobe Acrobat** for best results on either a Mac or PC. Visit <http://get.adobe.com/reader/> to download Adobe Reader for free. **Print** the files making sure that the document is at **100%**.

**PATTERN GRID MEASURES: 2.5cm x 2.5cm or 1" x 1"**.

*Please note: Page Scaling is usually on by default when printing and will print your pattern at the wrong size. Please make sure that Page scaling is disabled, by changing **PAGE SCALING TO NONE**.*

## ASSEMBLY

Prepare the printed pattern sheets by trimming off one side + either the top or the bottom to the bounding box. The remaining edges will assist in the pattern assembly. We recommend using a paper trimmer or a craft knife and ruler to trim the sheets.

On each sheet to be attached to another sheet, you'll find easy to follow registration marks – i.e. **2A to be joined up with 2A**. Use the diagram below to assist you in assembling the pattern. Align each printed sheet with the corresponding marker + grid lines, tape to secure. Once the pattern is assembled it is ready to use.

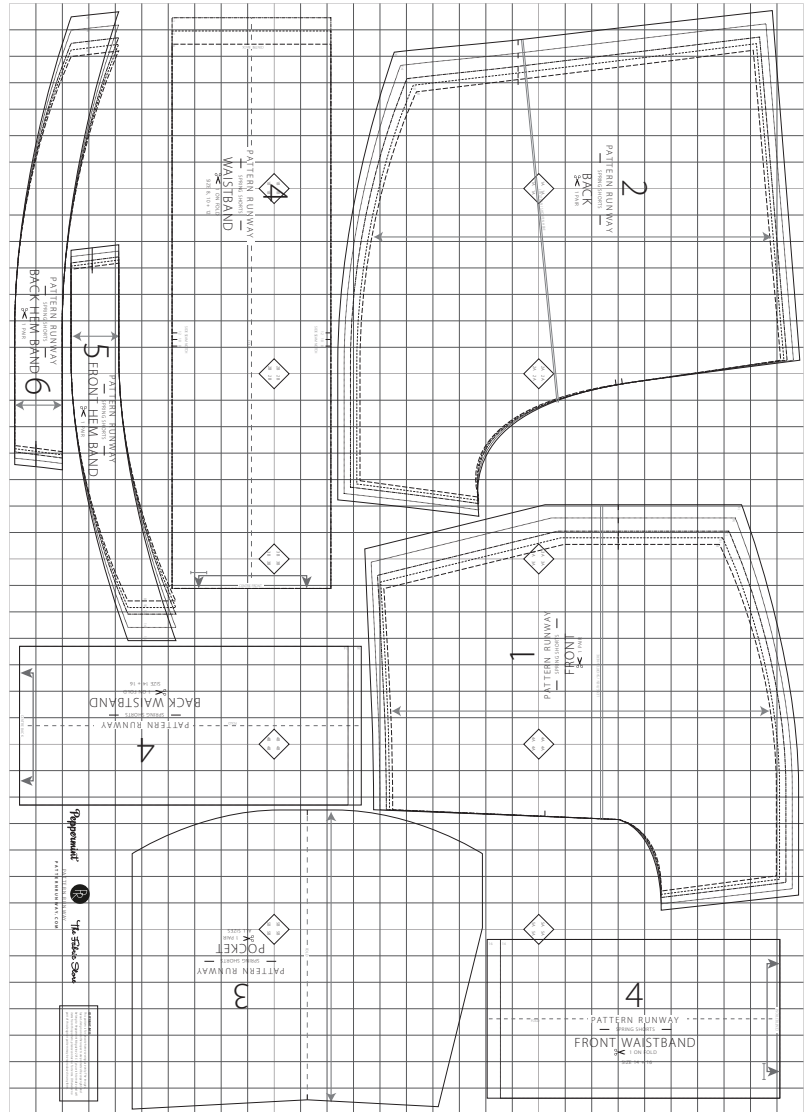

Peppermint



The Fabric Store

PATTERN  
RUNWAY

[www.patternrunway.com](http://www.patternrunway.com) | e: [sarah@patternrunway.com](mailto:sarah@patternrunway.com)

Fall in love with HandMade

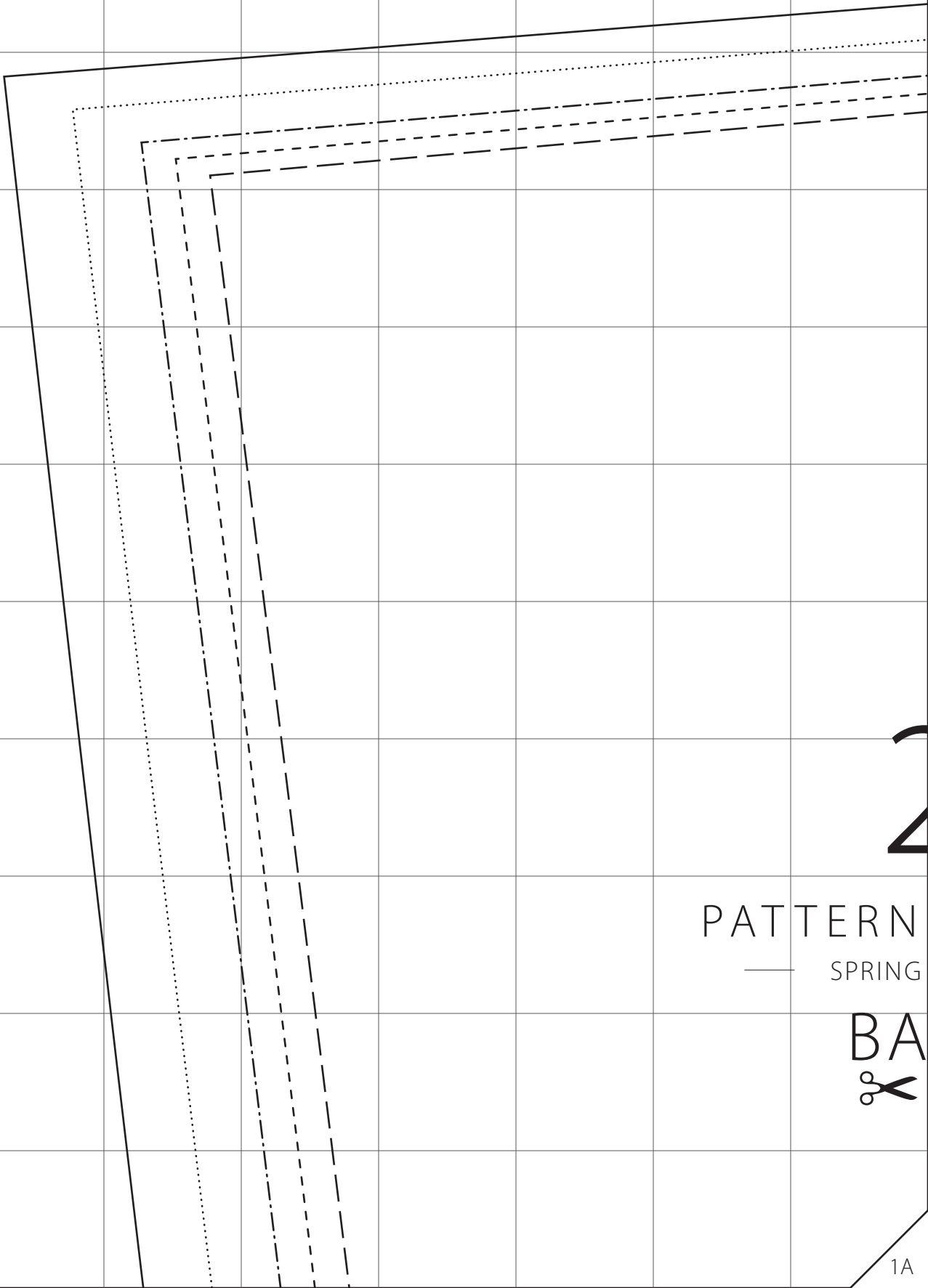

PATTERN

— SPRING

BA



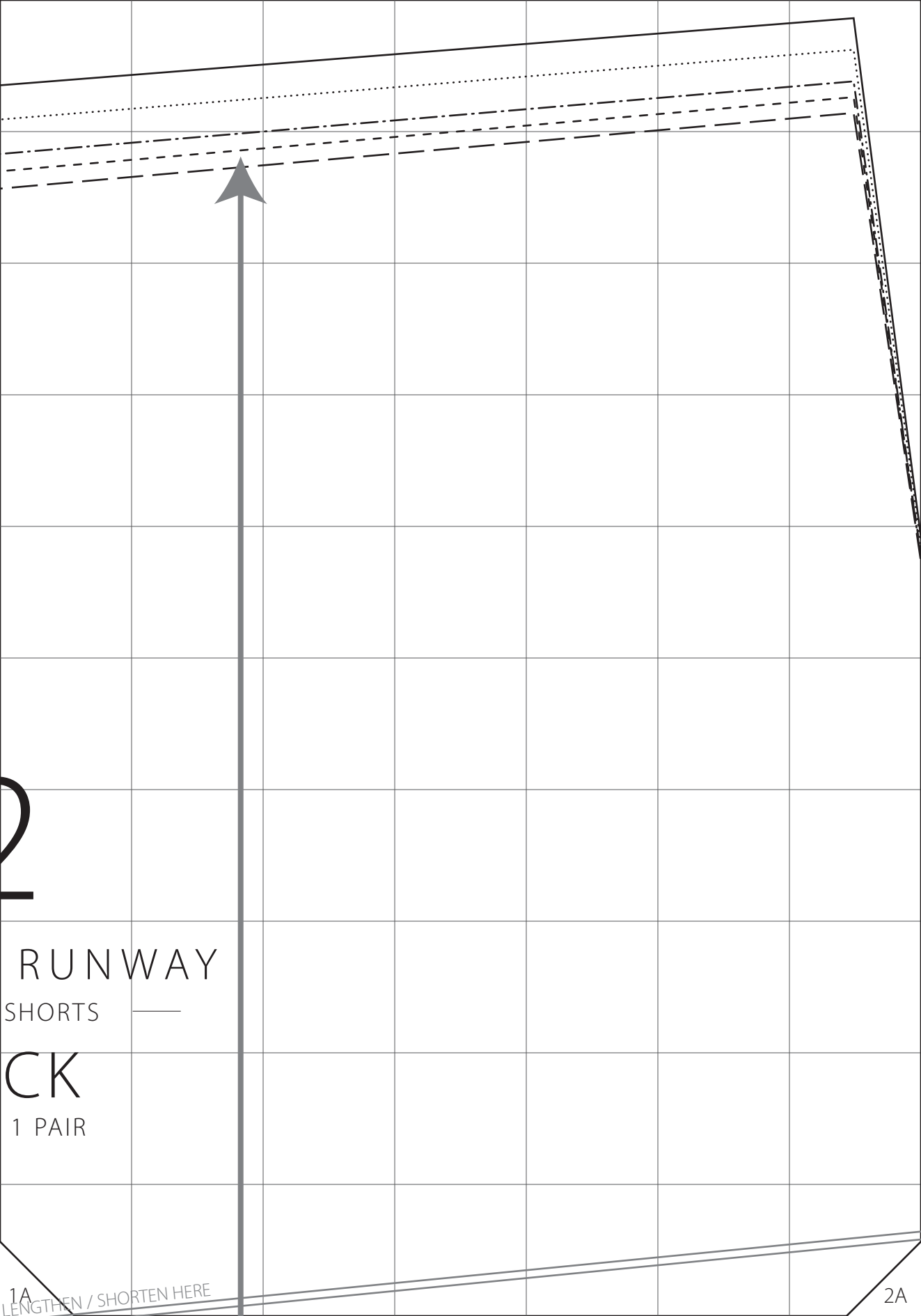

2

RUNWAY

SHORTS —

CK

1 PAIR

1A  
LENGTHEN / SHORTEN HERE

2A

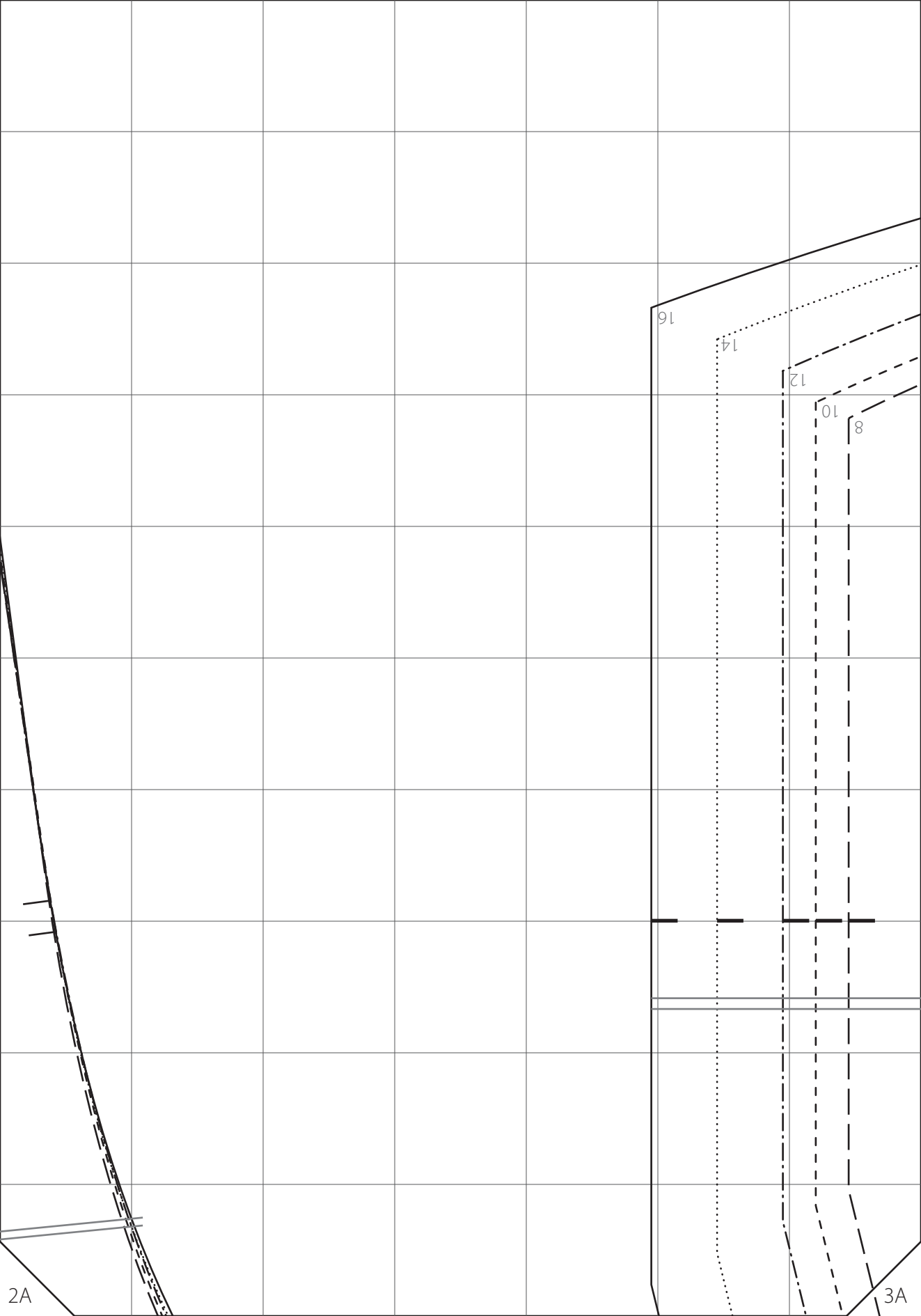

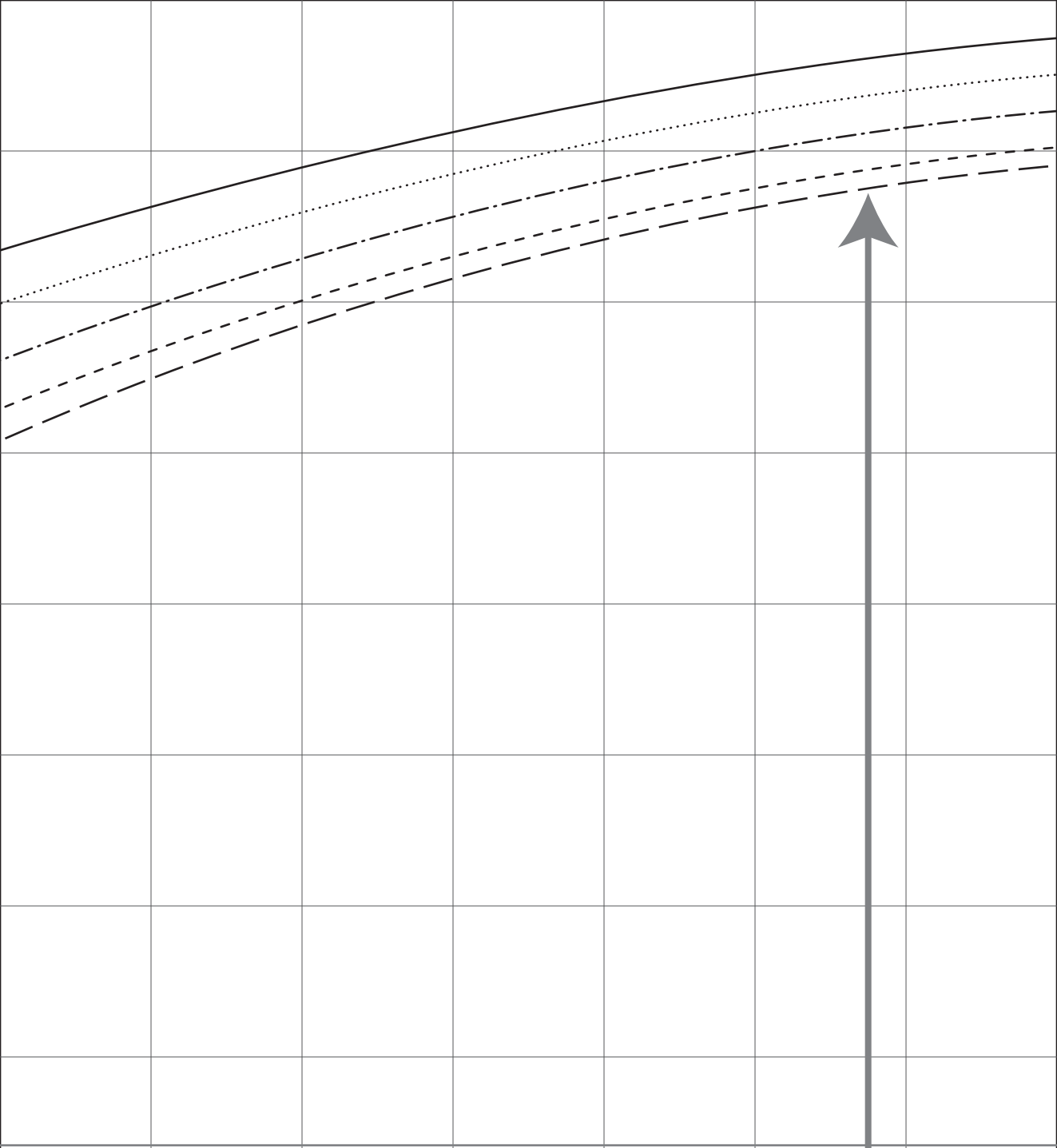

LENGTHEN / SHORTEN HERE



FRONT

SPRING SHORTS

PATTERN RUNWAY

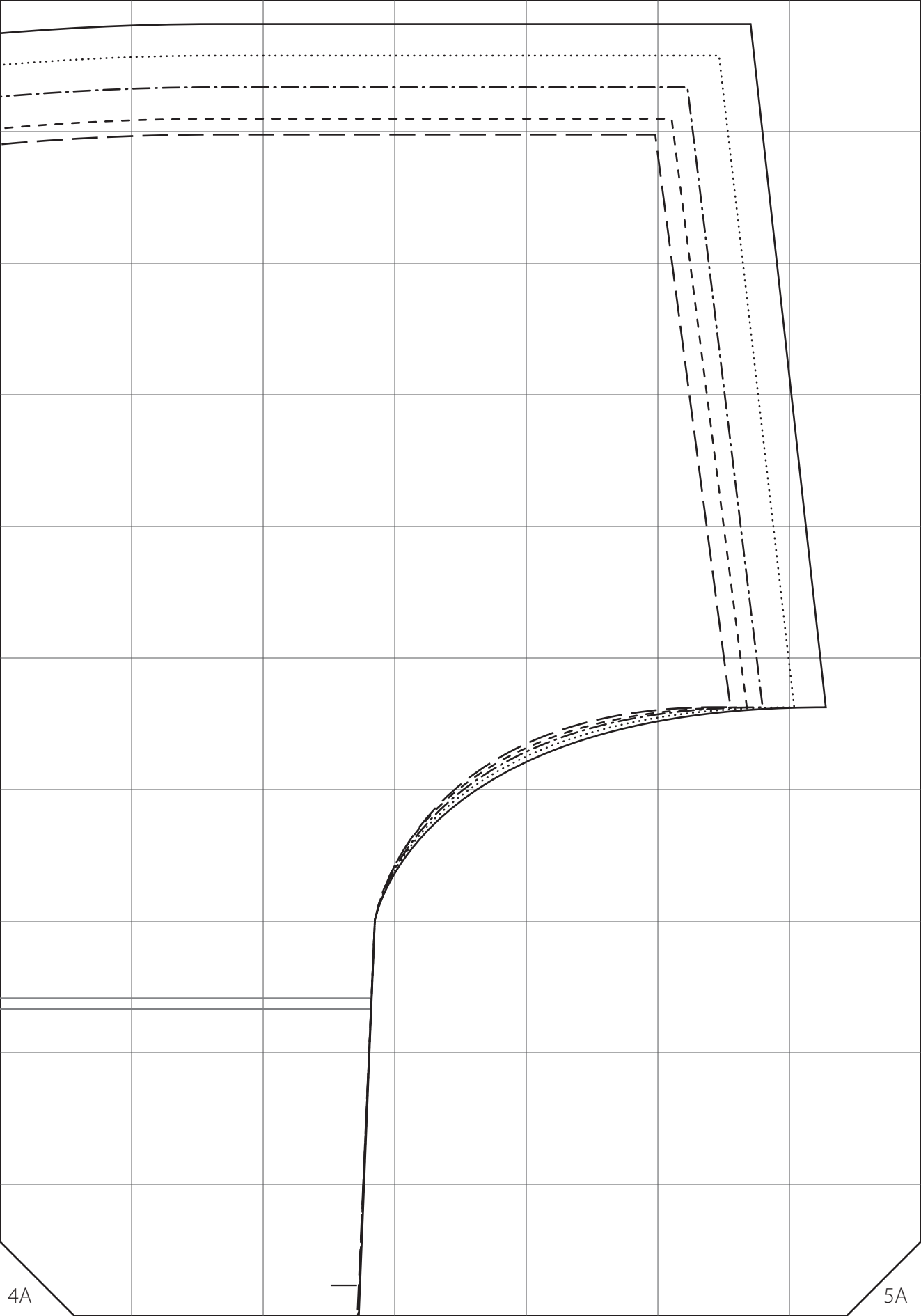

4A

5A

4

PATTERN RUNWAY

— SPRING SHORTS —

# FRONT WAISTBAND

✂ 1 ON FOLD

SIZE 14 + 16

CENTRE FRONT



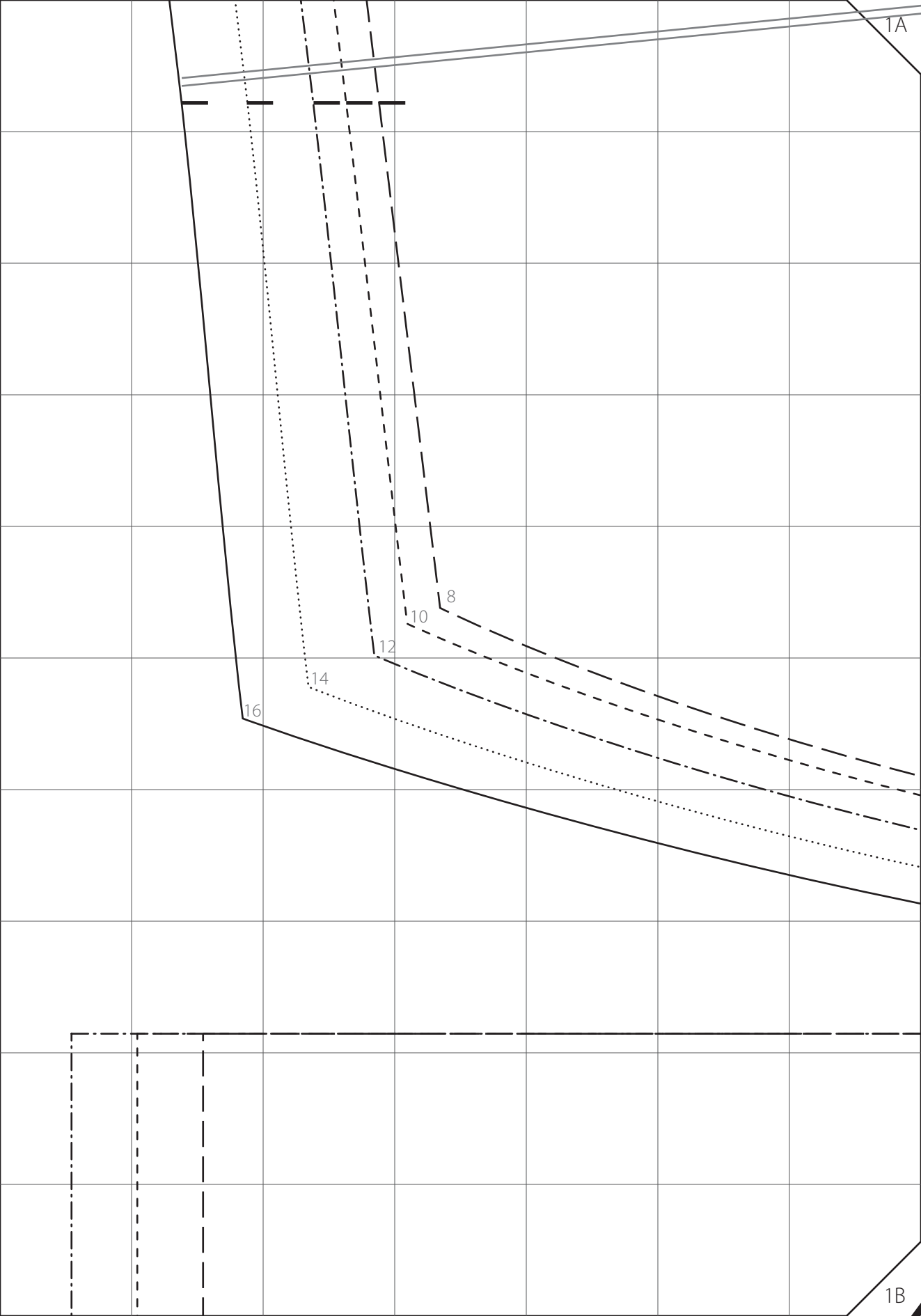

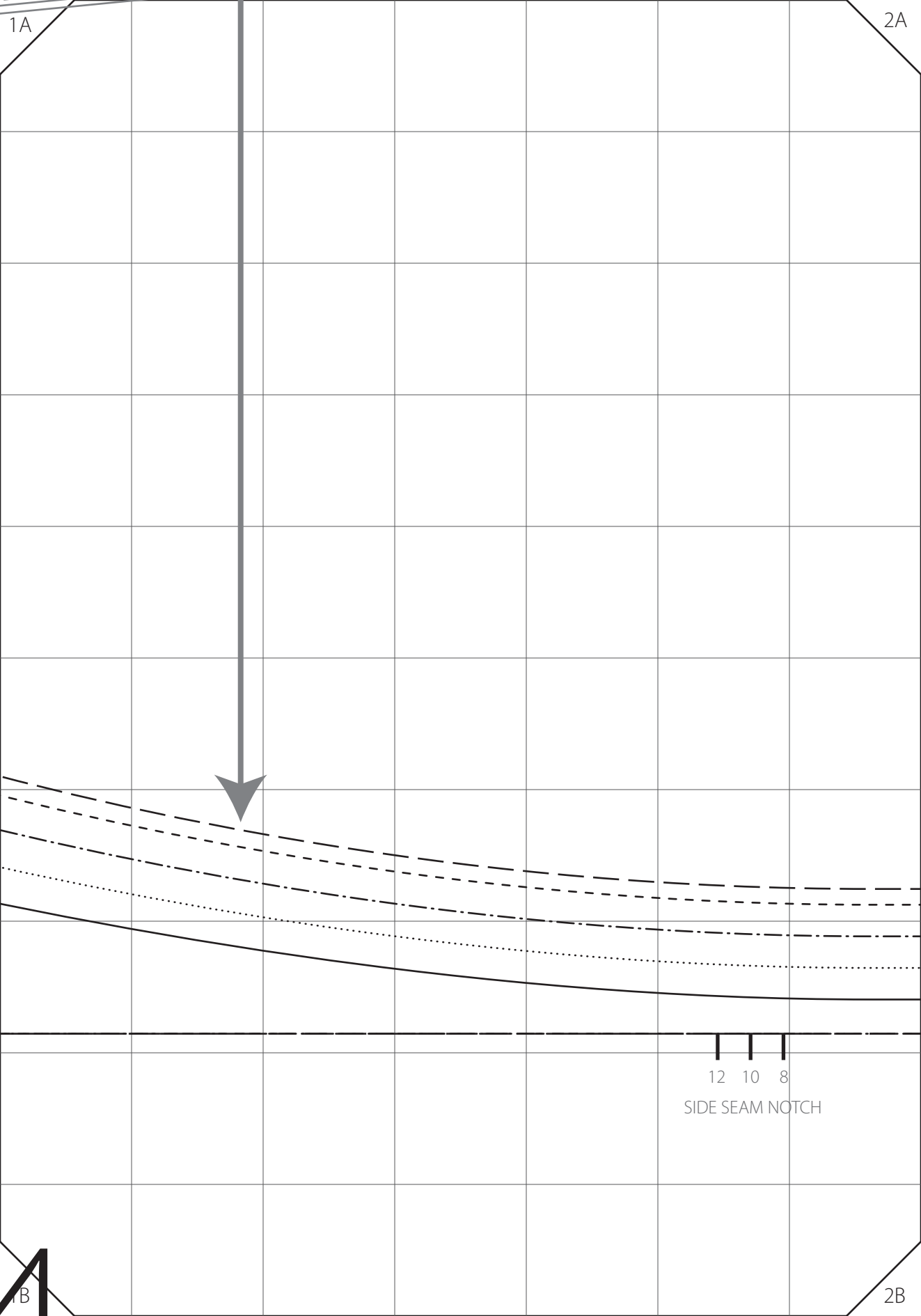

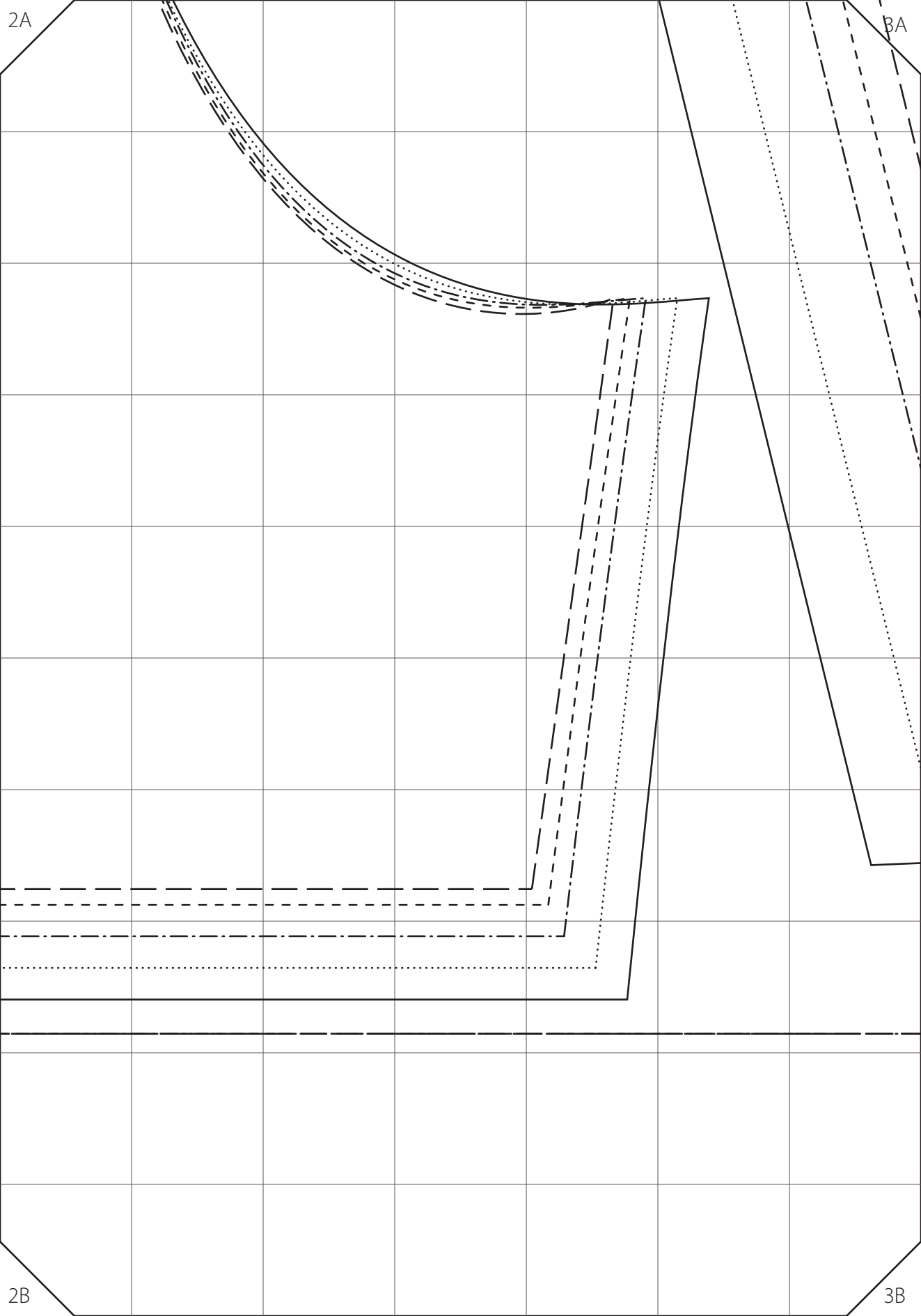

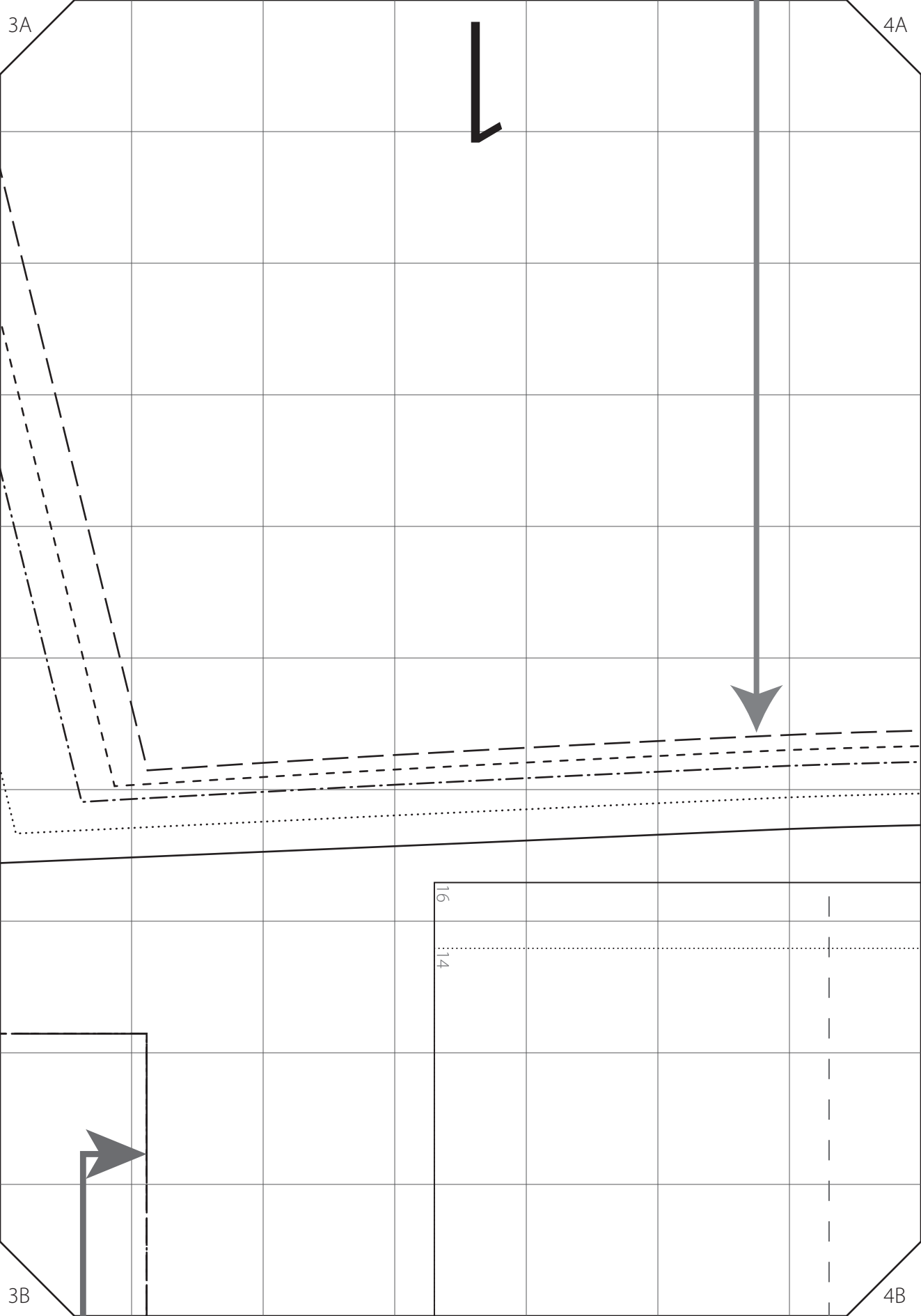



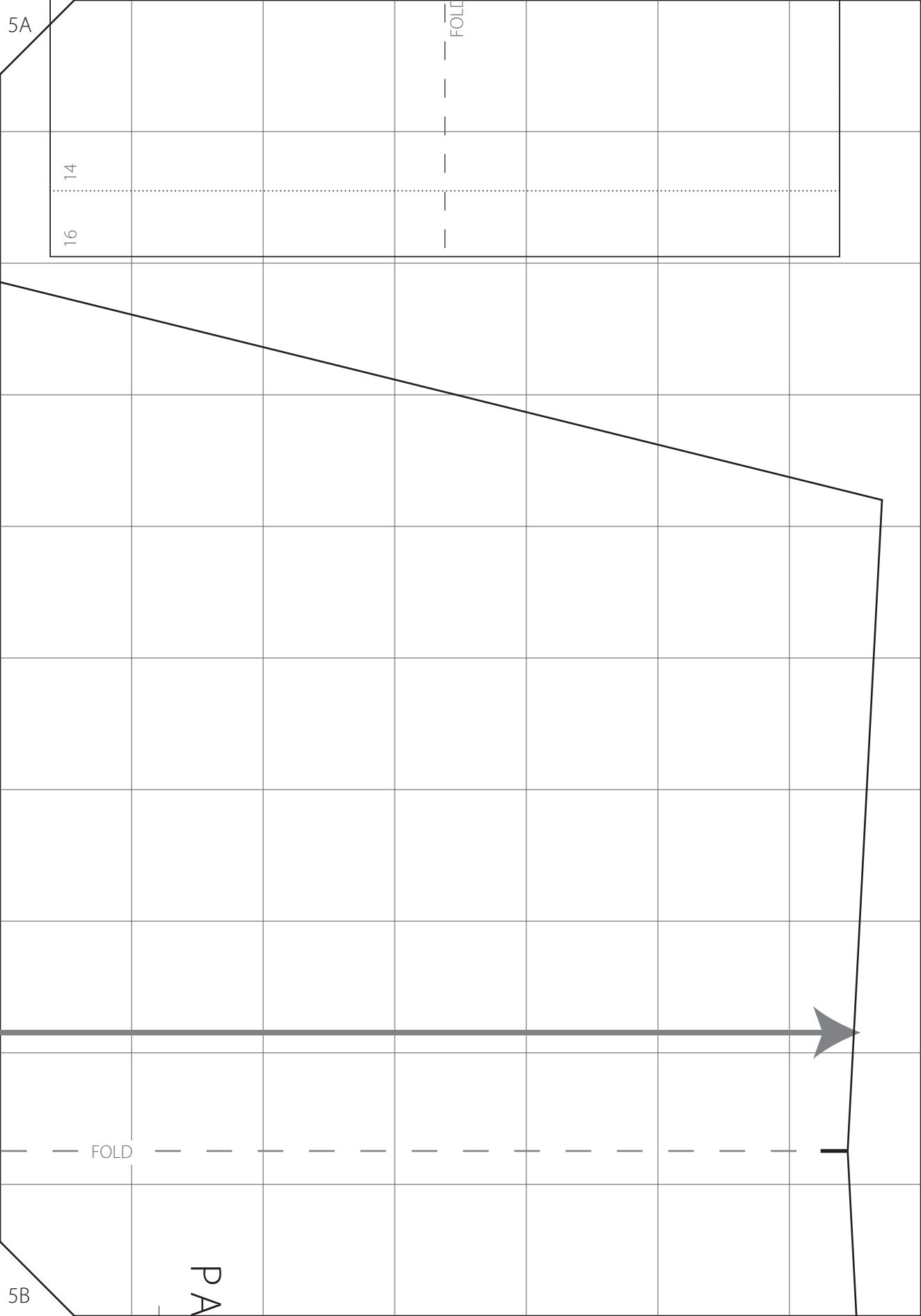

5A

14  
16

FOLD

FOLD

5B

PART



1B

PATTERN

SPRING

WAIST



SIZE

CENTRE BACK

12 10 8

16 14 12 10 8

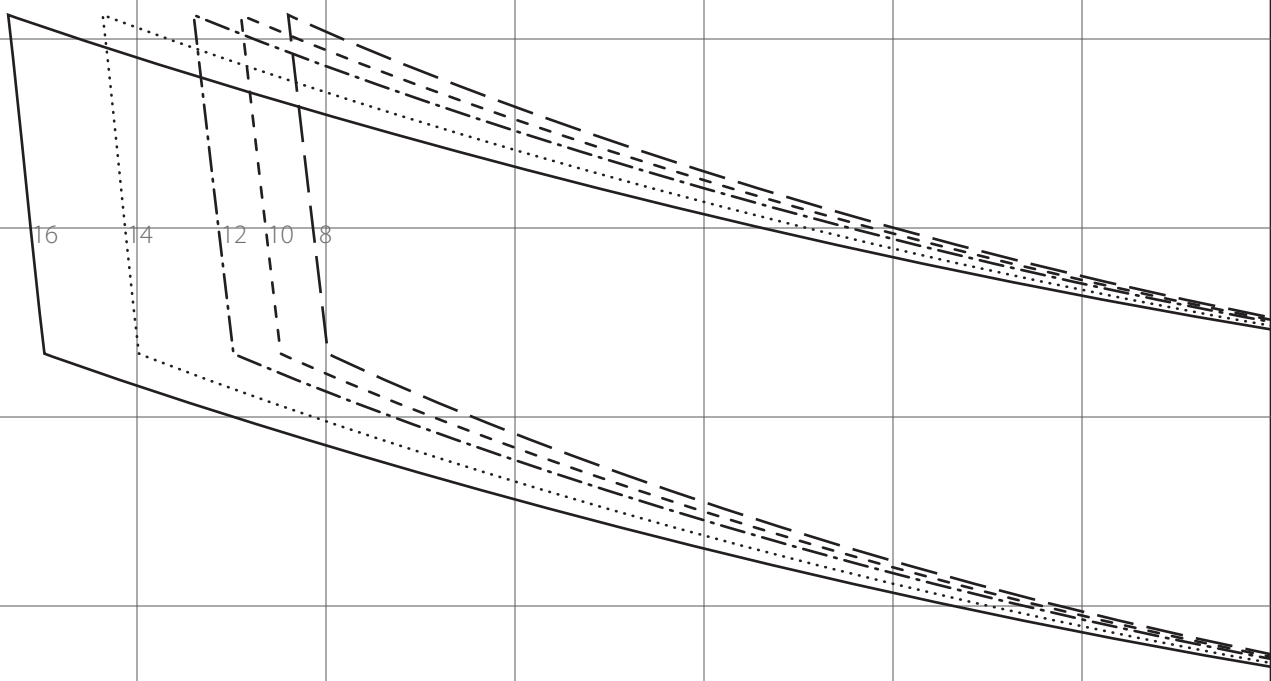

TB

2B

PATTERN RUNWAY

— SPRING SHORTS —

BACK HEM BAND

1 ON FOLD

8, 10 + 12



FOLD

SIDE SEAM NOTCH



PATTERN RUNWAY

— SPRING SHORTS —

BACK HEM BAND



1 PAIR



PATTERN RUNWAY  
 — SPRING SHORTS —  
 FRONT HEM BAND

 1 PAIR

6

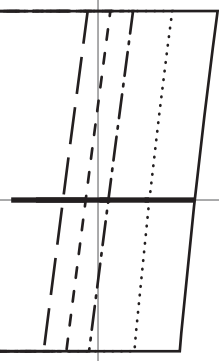

4B

FOLD

PATTERN RUNWAY

— SPRING SHORTS —

# BACK WAISTBAND

 1 ON FOLD

SIZE 14 + 16

CENTRE BACK



CENTRE FRONT

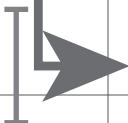

3B

16

14

12

10

8

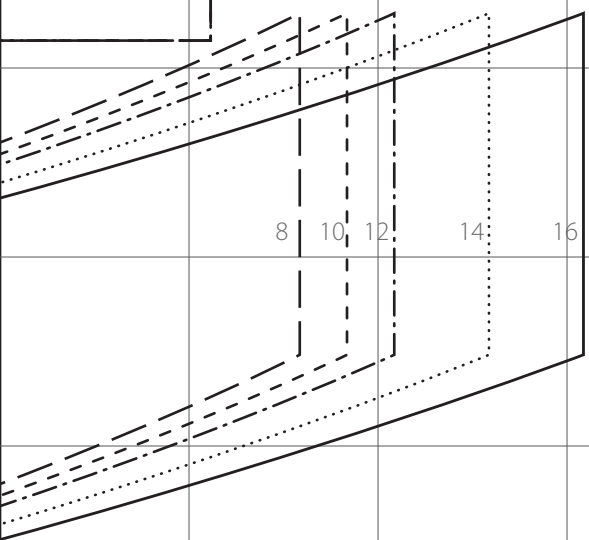

4B

5B



*Peppermint*



PATTERN RUNWAY  
PATTERNRUNWAY.COM

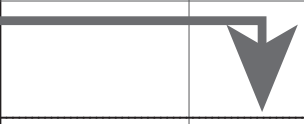

3

TERN RUNWAY  
— SPRING SHORTS —

POCKET

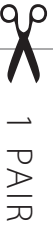

ALL SIZES

The Fabric Store

**COPYRIGHT INFO:**

*This pattern is for private home sewing use only. The images, layout, design and other aspects are protected by copyright and belong to Peppermint Magazine 2015. If you wish to make and sell items from this pattern, please contact us for terms. Otherwise no part of this design or pattern may be reproduced in any form.*